

AD-DRIVE-13: Matrix converter drive

Keywords: matrix converter, direct AC-AC converter

This matrix drive demo is composed of 18 IGBTs, MCTs, or even RB-IGBTs (reverse blocking IGBTs) grouped in pairs in series-parallel configuration with diodes (except in the case of RB-IGBT). An input filter and voltage clamp circuit complete the circuit.

This drive topology has some interesting characteristics: It has intrinsic power regeneration capabilities. It can have a smaller mounting place than conventional AC-AC converters because neither braking resistors nor large electrolytic capacitors are required. It has low total harmonics of input current with high efficiency and power factor. Also, because the matrix converter drive has no large DC-bus capacitor (usually electrolytic) it has a longer lifetime and is more reliable.

This matrix converter model can be accurate at a typical simulator time step (10 microseconds) and a typical matrix converter switching frequency (10 kHz), and the model takes into account multiple dead time effects occurring in matrix converters. It can also detect individual IGBT firing faults like load open-circuits and source short-circuits, and can operate independently from the commutation technique (e.g., with current commutation or voltage-based methods). Finally, it takes into account IGBT voltage offset and resistive voltage drops.

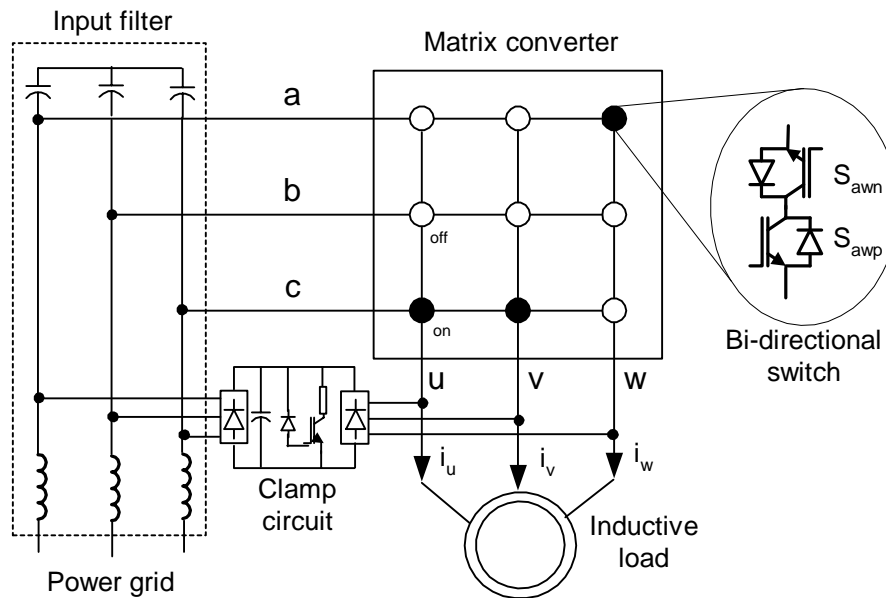

Figure 1. Matrix converter drive

System configuration	
Hardware enclosure	HILBox
Software modules	Time-stamped bridge, ARTEMIS
Additional models	N/A
Package	D