

PMSM inverter with AC-side diode rectifier

Keywords: Diode rectifier, 9 kHz PMSM drive, HIL simulation, small motor drive

This demo implements a permanent magnet motor drive fed by a 3-phase diode rectifier. The model runs on a dual-Xeon-based, 2.8 GHz, RT-LAB simulator with sample times of 10 microseconds for the motor inverter and 80 microseconds for the diode rectifier. The diode rectifier uses the ARTEMIS blockset to precompute all modes of the rectifier, thus removing SimPowerSystems mode computation from the real-time loop. An IGBT bridge using Time-Stamped Bridges is used to accurately compute the voltage-time application time to the motor model. This is important because if the model samples the IGBT gate signals at 10 microseconds without special care, important errors would occur in the motor flux computations with the PWM carrier set at 9 kHz (~110 microseconds period, ~10 times the simulation time step).

In August 2004, Opal-RT successfully created for Mitsubishi Electric Co. of Japan a real-time simulator running this model. The model is connected to a real external vector controller with a sampling rate of 55 microseconds. The external controller reads the motor currents and the quadrature encoder signals from the simulator and feeds the simulator with the 6 IGBT gate signals. The complete model runs in this HIL mode at a sample time of 10 microseconds for the CPU simulating the inverter and 80 microseconds for the CPU running the AC-side of the model.

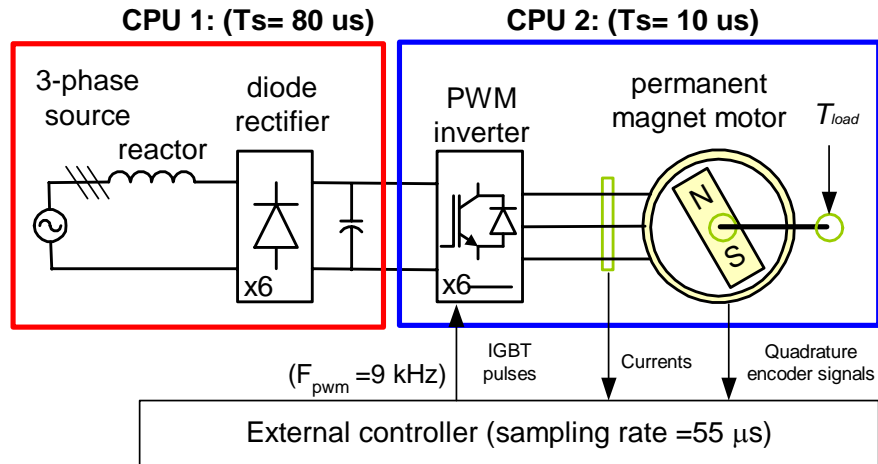

Figure 1. PMSM inverter with AC-side

System configuration	
Hardware enclosure	HILBox
Software modules	Time-stamped bridge, ARTEMIS
Additional models	N/A
Package	D